

AUTOMATIC SELF DRAINING FREEZE PROOF ROOF HYDRANT - HYDRANTS SHALL BE PROVIDED ON ALL ROOFS THAT HAVE ROOFTOP EQUIPMENT THAT REQUIRES SERVICING - WHERE POSSIBLE, LOCATE OVER JANITORS CLOSETS, RESTROOMS OR OTHER SERVICEABLE AREAS AND WITHIN A 200' RADIUS OF THE ROOFTOP EQUIPMENT THAT REQUIRES SERVICING - IF EQUIPMENT FALLS OUTSIDE OF THE 200' RADIUS, ADDITIONAL HYDRANTS ARE TO BE PROVIDED TO COVER ALL SUCH EQUIPMENT - HYDRANT SHALL BE PLUMBED DIRECTLY TO DRAIN, INDIRECT INTO MOP SINK, FUNNEL DRAIN, OR FLOOR SINK.

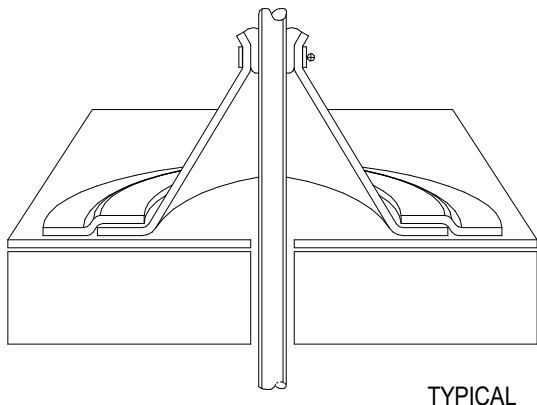

FLASHING MEMBRANE AND SEALANT
 STAINLESS STEEL CLAMPING RING
 SPM MEMBRANE BOOT WITH MINIMUM 1" TURN-UP
 CONTINUOUS WELD TO PVC COATED METAL
 8" MIN.

HEAT WELDED FLASHING
 ROOFING MEMBRANE - VARIES BY PROJECT

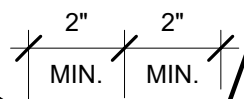

RIGID INSULATION - VARIES BY PROJECT

ROOF DECK VARIES BY PROJECT

INSTALL HYDRANT PER MANUFACTURERS RECOMMENDATIONS - VARIES BY MANUFACTURER AND BY ROOFING / DECK SYSTEM

ROUTE AUTOMATIC DRAIN TO NEAREST MOP SINK, FLOOR SINK, OR FUNNEL DRAIN - PROVIDE 2" AIR GAP